

Synchronising pulleys easy drive® AT-profile

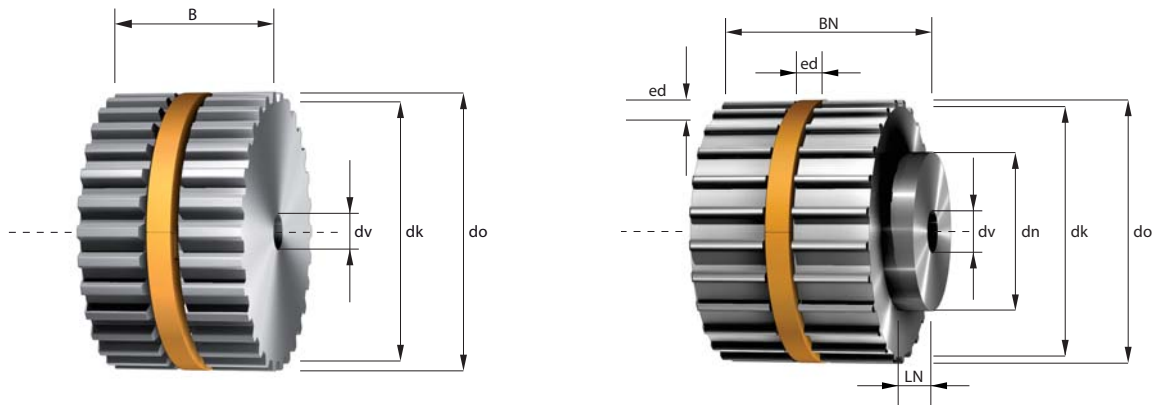

- z = Number of teeth
- dk = Outside diameter
- do = Pitch diameter
- ed = easy drive® groove
- dv = Diameter of pre-bore
- dmax = max. bore diameter without feather key groove
- dh = Hub diameter
- wh = Hub width

Groove base to max. bore diameter min. 3-4 mm wall thickness

Materials: Stock pulleys - aluminium; special pulleys - steel, gray cast iron, plastics
 Stock rings easy drive® - plastic; special rings - aluminium and steel

AT 3	Belt width = b (mm)	16	25	32	50
	Total width = B (mm)	18	27	34	52
	Total width with hub = BN (mm)	24	33	40	58

Starting from z = 22

Min. diameter of the tension rollers without contra-flexure 15 mm, with contra-flexure 20 mm.

AT 5	Belt width = b (mm)	16	20	25	32	50	75	100	150
	Total width = B (mm)	18	22	27	34	52	77	102	152
	Total width with hub = BN (mm)	24	28	33	40	58	83	108	158

Starting from z = 14

Min. diameter of the tension rollers without contra-flexure 18 mm, with contra-flexure 60 mm.

AT 10	Belt width = b (mm)	16	25	32	50	75	100	150
	Total width = B (mm)	18	27	34	52	77	102	152
	Total width with hub = BN (mm)	28	37	44	62	87	112	162

Starting from z = 12

Min. diameter of the tension rollers without contra-flexure 50 mm, with contra-flexure 120 mm.

AT 20	Belt width = b (mm)	16	25	32	50	75	100	125	150
	Total width = B (mm)	18	27	34	52	77	102	127	152
	Total width with hub = BN (mm)	28	37	44	62	87	112	137	162

Starting from z = 18

Min. diameter of the tension rollers without contra-flexure 120mm, with contra-flexure 180 mm.